

# ALK-SIM™

## Alkylation Operations

a KBC SIM Model

ALK-SIM is the KBC simulator for hydrofluoric acid or sulphuric acid alkylation operations. The refrigeration section of the sulphuric acid units may be modelled rigorously with the Petro-SIM flowsheet unit operations. ALK-SIM is designed to allow users to monitor daily operations and evaluate alternative alkylation unit operating strategies. For specified feeds, operating conditions, and constraints, the programme determines resulting product flows and properties and overall unit operating economics.

### FEATURES

ALK-SIM contains the following key features:

- A yields model that calculates the impact of feed compositions and operating conditions on the production of isomers up to C<sub>8</sub> range and pseudocomponents up to C<sub>13</sub>
- Detailed product property predictions, including densities, total reactor effluent distillations, C<sub>5</sub>-composition, RON, MON, and RVP
- The model predicts the acid consumption, acid soluble oil (ASO) production and other key operating parameters
- Easy evaluation of multiple feeds of varying compositions from various sources can be evaluated
- Since ALK-SIM is integrated with Petro-SIM, interactions of iC<sub>4</sub> recycle and fractionator operation to the alkyla-

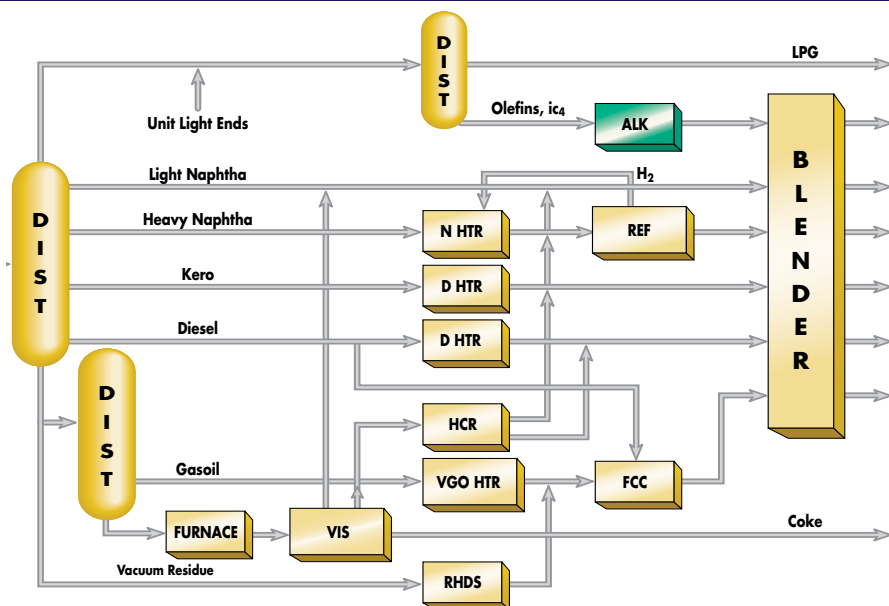

*ALK-SIM is a valuable tool to evaluate different feed compositions and their resulting yields and operation costs.*

tion reactor can be studied; for H<sub>2</sub>SO<sub>4</sub> units, the refrigeration circuit may also be simulated

- Optimisation of the alkylation operation can be conducted using the Petro-SIM optimiser
- Training of engineers and operators new to alkylation operations is also a potential application of the simulator. Users develop a sense of cause-and-effect by making a series of simulation runs

### Petro-SIM FLOWSHEET

ALK-SIM is available within Petro-SIM, the KBC process

*(Continued)*

flowsheet simulator. You can model the alkylation reactor section as an individual unit, or within a larger flowsheet to examine interactions between key units or over the entire facility.

## BENEFITS

ALK-SIM is a decision support tool to help answer the following questions:

- Selection of Operating Targets** – What are the effects of increasing the  $iC_4$ /olefin ratio by changing recycle rate? What is the effect of changing reactor temperature? What is the effect of changing acid strength?
- Evaluation of New Feeds/Products/Cutpoints** – What are the effects of a new feed on alkylate product qualities and yields? What are the yields/properties for  $C_3/C_4/C_5$  olefin feeds?
- LP Model Coefficients** – What vectors are needed to model the incremental yields for different olefin

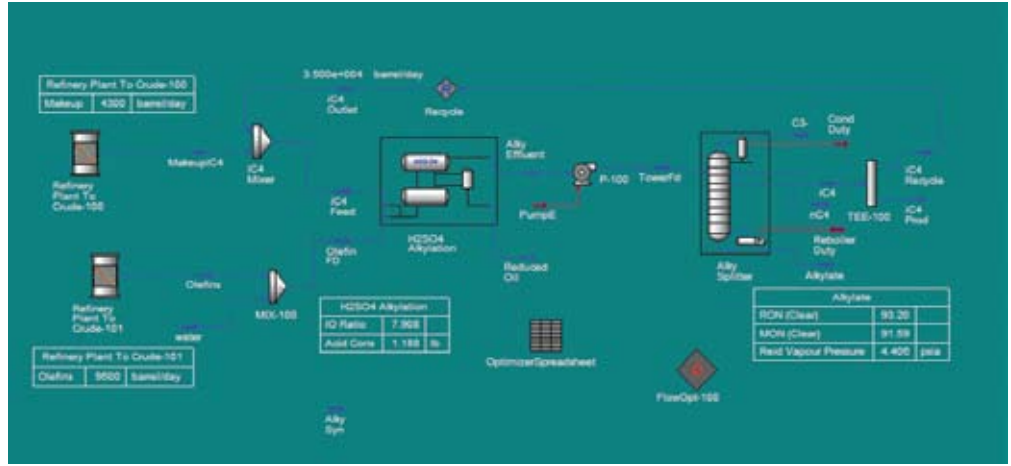

ALK-SIM PFD

feeds and operating conditions in the LP?

- Debottlenecking** – What are the economic effects of recycling more  $iC_4$ , increasing acid strength, or lowering reactor temperature? What are the economics of alternate reactor configurations?

Results	Calculated
C5+ Alkylate	Yield (barrel/day) 6524
Operating Summary	Specific Gravity 0.6994
Acid Data	API Gravity 70.82
Reactor Summary	Molecular Weight 107.0
Diagnostics	Reid Vapour Pressure (psia) 3.653
	Research Octane Number (Clear) 92.37
	Motor Octane Number (Clear) 90.31
	Residue (C10+) (wt %) 9.008
	TBP EndPoint (F) 366.4

C5+ Properties are alter any feed pentanes have been backed out.

Results View

## PREDICTIVE TECHNOLOGY FOR PROFIT IMPROVEMENT

- Petro-SIM™ for Process Simulation
- Petro-SIM Express™ for Process Simulation
- KBC SIM Suite:
  - FCC-SIM™ for Fluid Catalytic Cracking
  - REF-SIM™ for Catalytic Reforming
  - HCR-SIM™ for Hydrocracking
  - N HTR-SIM™, D HTR-SIM™ and VGO HTR-SIM™ for Hydrotreating
  - DC-SIM™ for Delayed Coking
  - VIS-SIM™ for Visbreaking and Thermal Cracking
  - ALK-SIM™ for Alkylation
  - RHDS-SIM™ for Residue Hydrotreating
  - AROM-SIM™ for Aromatics
  - ISOM-SIM™ for Isomerisation
  - Olefin-SIM™ for Pyrolysis



www.kbcat.com • www.petro-sim.com • software@kbcat.com  
 AMERICAS +1 281 293 8200 • ASIA +65 6735 5488 • EMEA +44 (0) 1932 242424

™ Petro-SIM, Petro-SIM Express, FCC-SIM, REF-SIM, HCR-SIM, HTR-SIM, DC-SIM, VIS-SIM, ALK-SIM, RHDS-SIM, AROM-SIM, ISOM-SIM, and Olefin-SIM are trademarks of KBC Advanced Technologies plc, and they are registered in various territories

© Excel is a registered trademark of Microsoft Corporation