

VIS-SIM™

Visbreaking Operations

a KBC SIM Model

VIS-SIM is the KBC simulator for visbreaker operations. VIS-SIM can model either coil-type or soaker-type configurations, including the furnace and an optional soaker drum.

The model predicts yield and product properties, given feed quality, furnace outlet temperature or severity, and unit geometry. The key properties of visbroken tar viscosity and stability are predicted. Detailed fractionation can be added up- or downstream of the unit.

FEATURES

VIS-SIM contains the following key features:

- A tube-by-tube simulation of the furnace, allowing estimations of skin and bulk flow temperatures, as well as pressure drop and key parameters affecting coke laydown, like oil film temperature and tube residence time
- A first-principles kinetic approach in modelling the key thermal cracking reactions and the resulting conversions to gas, naphtha, and gas oil
- Detailed yields and product property estimates, including densities, sulphurs, and distillations; key fuel oil properties include fuel oil stability, asphaltene content, Conradson carbon content, and viscosity

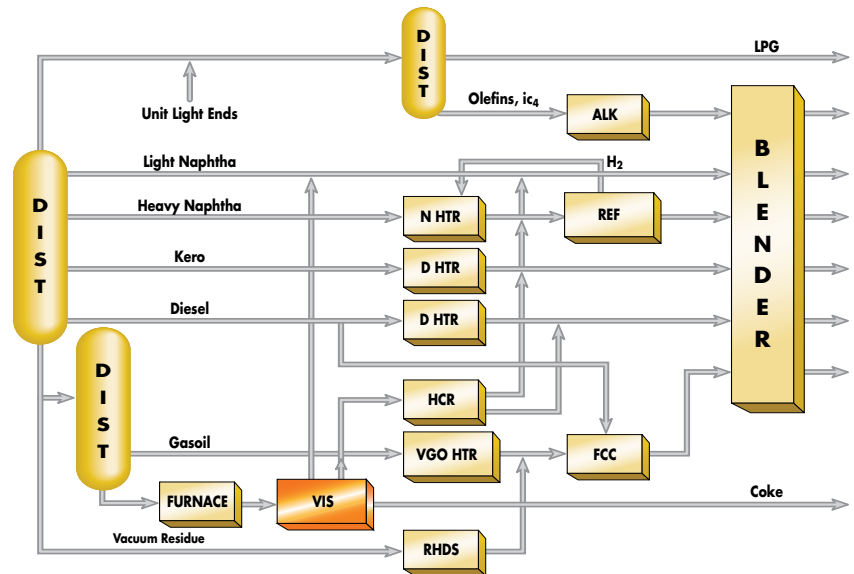

VIS-SIM is a valuable tool to evaluate different visbreaking operations and the resulting products.

Petro-SIM FLOWSHEET

VIS-SIM is available within Petro-SIM, the KBC process flowsheet simulator. You can model the Visbreaker as an individual unit, or within a larger flowsheet to examine interactions between key units or over the entire facility.

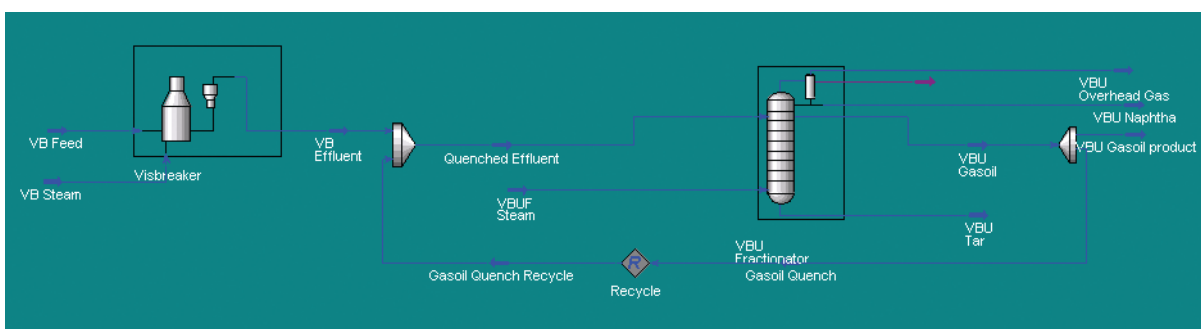

VIS-SIM PFD

BENEFITS

(Continued)

VIS-SIM is a decision support tool to help answer the following questions:

- What is the most profitable operation of the visbreaker for a particular feed, given heater, fuel oil specifications, and fractionation capacity constraints, as well as cutter stocks for blending?
- What is the impact of operating and design changes on furnace tube skin and oil film temperatures and pressure drop?
- How much do furnace flux rates and coil outlet temperature need to be increased in order to achieve a target increase in conversion?
- What is the optimum crude slate selection to generate a consistent set of visbreaker yields?
- How can LP vectors be improved and updated for better crude selection?

Operating Parameters

	Fluid P [psia]	Fluid T [F]	Oil Film T [F]	LV% Vaporised [vol %]	Fluid Velocity [ft/s]	Sonic Velocity [ft/s]	Residence Time [seconds]
Outlet 1	99.56	860.0	860.0	33.5	0.9	729.4	74.70
Inlet 1	99.56	885.1		20.4	0.6	737.8	
Outlet 2	101.60	886.0	893.8	18.7	56.8	694.7	3.475
Inlet 2	110.41	887.0		16.0	47.1	704.8	
Outlet 3	110.61	887.0	912.0	16.0	36.0	705.0	1.800
Outlet 4	114.85	883.4	909.4	14.4	32.4	713.0	1.999
Outlet 5	118.68	879.9	906.9	12.9	29.1	721.7	2.217
Outlet 6	122.11	876.2	904.3	11.5	26.4	730.3	2.450
Outlet 7	125.23	872.4	901.5	10.2	23.9	739.4	2.712
Outlet 8	128.04	868.6	898.9	9.0	21.5	749.5	3.000
Outlet 9	130.59	864.6	895.9	7.8	19.5	759.8	3.314
Outlet 10	132.90	860.6	892.9	6.8	17.6	771.2	3.663
Outlet 11	134.98	856.5	889.9	5.8	15.9	783.7	4.053
Outlet 12	136.88	852.2	886.7	4.9	14.4	797.3	4.489
Outlet 13	138.59	848.0	883.5	4.0	13.0	812.0	4.976
Outlet 14	140.13	843.6	880.1	3.3	11.7	828.9	5.519
Outlet 15	141.53	839.3	876.7	2.6	10.6	847.7	6.127

Results View

PREDICTIVE TECHNOLOGY FOR PROFIT IMPROVEMENT

- Petro-SIM™ for Process Simulation
- Petro-SIM Express™ for Process Simulation
- KBC SIM Suite:
 - FCC-SIM™ for Fluid Catalytic Cracking
 - REF-SIM™ for Catalytic Reforming
 - HCR-SIM™ for Hydrocracking
 - N HTR-SIM™, D HTR-SIM™ and VGO HTR-SIM™ for Hydrotreating
 - DC-SIM™ for Delayed Coking
- VIS-SIM™ for Visbreaking and Thermal Cracking
- ALK-SIM™ for Alkylation
- RHDS-SIM™ for Residue Hydrotreating
- AROM-SIM™ for Aromatics
- ISOM-SIM™ for Isomerisation
- Olefin-SIM™ for Pyrolysis



www.kbc.cat.com • www.petro-sim.com • software@kbc.cat.com
 AMERICAS +1 281 293 8200 • ASIA +65 6735 5488 • EMEA +44 (0) 1932 242424

™ Petro-SIM, Petro-SIM Express, FCC-SIM, REF-SIM, HCR-SIM, HTR-SIM, DC-SIM, VIS-SIM, ALK-SIM, RHDS-SIM, AROM-SIM, ISOM-SIM, and Olefin-SIM are trademarks of KBC Advanced Technologies plc, and they are registered in various territories

© Excel is a registered trademark of Microsoft Corporation